



길 우 트 레 이 덩

서울특별시 영등포구 선유로33길 15
703호(양평동3가, 에이스테크노타워)<150-962>

02)2636-0009 팩스02)2636-4753

www.gilwoo.co.kr giltron@naver.com
www.gilwooshop.co.kr

©2005-2012 Applent Instruments LLC.

Rev. C1

[AT520/AT520SE/AT520L/AT520M AC Milliohm Meter]

USER'S GUIDE

Safety Summary

 Warning  Dangerous :

When you notice any of the unusual conditions listed below, immediately terminate operation and disconnect the power cable.

Please Contact Applent Instruments Incorporation sales representative for repair of the instrument. If you continue to operate without repairing the instrument, there is a potential fire or shock hazard for operators.

Instrument operates abnormally.

Instrument emits abnormal noise, smell, smoke, or a spark-like light during the operation.

Instrument generates high temperature or electrical shock during operation.

Power cable, plug, or receptacle on instrument is damaged.

Foreign substance or liquid has fallen into the instrument.

Safety Summary

Warning Dangerous :

The following general safety precautions must be observed during all phases of operation, service, and repair of this instrument. Failure to comply with these precautions or with specific WARNINGS elsewhere in this manual may impair the protection provided by the equipment. In addition it violates safety standards of design, manufacture, and intended use of the instrument.

Disclaimer	<i>The Applent Instruments assumes no liability for the customer's failure to comply with these requirements.</i>
Ground The Instrument	To avoid electric shock hazard, the instrument chassis and cabinet must be connected to a safety earth ground by the supplied power cable with earth blade.
DO NOT Operate In An Explosive Atmosphere	Do not operate the instrument in the presence of inflammable gasses or fumes. Operation of any electrical instrument in such an environment constitutes a definite safety hazard.
Keep Away From Live Circuits	Operating personnel must not remove instrument covers. Component replacement and internal adjustments must be made by qualified maintenance personnel. Do not replace components with the power cable connected. Under certain conditions, dangerous voltages may exist even with the power cable removed. To avoid injuries, always disconnect power and discharge circuits before touching them.
DO NOT Service Or Adjust Alone	Do not attempt internal service or adjustment unless another person, capable of rendering first aid and resuscitation, is present.
DO NOT Substitute Parts Or Modify Instrument	Because of the danger of introducing additional hazards, do not install substitute parts or perform unauthorized modifications to the instrument. Return the instrument to an Applent Instruments Sales and Service Office for service and repair to ensure that safety features are maintained.

CERTIFICATION, LIMITED WARRANTY, & LIMITATION OF LIABILITY

Applent Instruments, Inc. (shortened form **Applent**) certifies that this product met its published specifications at the time of shipment from the factory. Applent further certifies that its calibration measurements are traceable to the People's Republic of China National Institute of Standards and Technology, to the extent allowed by the Institution's calibration facility or by the calibration facilities of other International Standards Organization members.

This Applent instrument product is warranted against defects in material and workmanship for a period corresponding to the individual warranty periods of its component products. **The warranty period is 2 years and begins on the date of shipment.** During the warranty period, Applent will, at its option, either repair or replace products that prove to be defective. This warranty extends only to the original buyer or end-user customer of a Applent authorized reseller, and does not apply to fuses, disposable batteries or to any product which, in Applent's opinion, has been misused, altered, neglected or damaged by accident or abnormal conditions of operation or handling.

For warranty service or repair, this product must be returned to a service facility designated by Applent. The buyer shall prepay shipping charges to Applent and Applent shall pay shipping charges to return the product to the Buyer. However, the Buyer shall pay all shipping charges, duties, and taxes for products returned to Applent from another country.

Applent warrants that its software and firmware designated by Applent for use with an instrument will execute its programming instruction when properly installed on that instrument. Applent does not warrant that the operation of the instrument, or software, or firmware, will be uninterrupted or error free.

The foregoing warranty shall not apply to defects resulting from improper or inadequate maintenance by the Buyer, Buyer-supplied software or interfacing, unauthorized modification or misuse, operation outside the environmental specifications for the product, or improper site preparation or maintenance.

THIS WARRANTY IS BUYER'S SOLE AND EXCLUSIVE REMEDY AND IS IN LIEU OF ALL OTHER WARRANTIES, EXPRESS OR IMPLIED, INCLUDING BUT NOT LIMITED TO ANY IMPLIED WARRANTY OF MERCHANTABILITY OR FITNESS FOR A PARTICULAR PURPOSE. APPLMENT SHALL NOT BE LIABLE FOR ANY SPECIAL, INDIRECT, INCIDENTAL OR CONSEQUENTIAL DAMAGES OR LOSSES, INCLUDING LOSS OF DATA, WHETHER ARISING FROM BREACH OF WARRANTY OR BASED ON CONTRACT, TORT, RELIANCE OR ANY OTHER THEORY.

Applent Instruments, Inc.
Changzhou,
Jiangsu,
The People's Republic of China.
Rev.A2 January, 2005
Rev.B0 January, 2008

Contents

Safety Summary	2
Safety Summary	3
CERTIFICATION, LIMITED WARRANTY, & LIMITATION OF LIABILITY	4
Contents	5
Figure Contents.....	7
Table Contents	7
1. Unpacking and Preparation.....	8
1.1 Incoming Inspection	8
1.2 Setting up Fuse	8
1.3 Environmental Requirements	9
1.4 Cleaning.....	9
1.5 How to Remove the Handle.....	9
2. Overview	11
2.1 Introduction.....	11
2.2 Functional Comparison.....	11
2.3 Main Specifications and Features	11
3. Start up.....	13
3.1 Front panel	13
3.2 Real panel	14
3.3 Keypad I.....	14
3.4 VFD	15
3.5 Power On/Off.....	16
3.5.1 Warm-up Time	16
4. Configuration.....	17
4.1 Connect to Device under Test (DUT)	17
4.2 Setting the Measurement Range	17
4.3 Setting the Sampling Rate.....	18
4.4 Short Clear Zero Correction	18
4.5 Choose Measure Parameter (AT520)	18
4.6 Relative value	19
4.7 Voltage Limiter	19
4.8 Set beep ON/OFF	19
4.9 Deviation Display Mode.....	19
4.10 Lock out the keypad.....	20
5. Comparator	21
5.1 Turn ON/OFF the Comparator.....	21
5.2 Setup the record number and comparator	21
5.3 Setup Beeper.....	21
5.4 How the comparator work	22
6. Handler Interface (AT520).....	23
6.1 Pin Assignment	23
6.2 Connection method.....	24
6.3 Power Rating	24
6.4 Electrical Characteristics	25
6.4.1 Input Signal:.....	25
6.4.2 Output Signal:.....	25
6.4.3 Power supply	25
6.5 Timing Chart.....	25
7. Remote Control.....	27
7.1 About RS-232C	27
7.2 Enable RS-232C Interface and select baud rate.....	27
7.3 SCPI Language	28
8. Command Reference	29
8.1 Terminator.....	29
8.2 Notation Conventions and Definitions.....	29
8.3 Command Structure	29
8.4 Header and Parameters	31

8.5	Command Reference.....	31
8.6	FUNCTION Subsystem.....	32
8.6.1	:RANGe:AUTO.....	32
8.6.2	:RANGe.....	33
8.6.3	:RATE.....	33
8.6.4	:DEV.....	33
8.6.5	:CURRentmode.....	33
8.7	TRIG Subsystem.....	34
8.7.1	:SOURce.....	34
8.8	BEEPer Subsystem.....	34
8.8.1	:BINmode.....	35
8.9	FETCh Subsystem.....	35
8.10	ERRor Subsystem.....	36
8.11	*IDN? Common Command.....	36
8.12	*RST Common Command.....	36
8.13	*TRG Common Command.....	36
9.	Specification.....	38
9.1	AT520 Specification.....	38
9.2	AT520SE Specification.....	38
9.3	AT520L Specification.....	39
9.4	AT520M Specification.....	39
9.5	General Specification.....	40
9.6	Dimensions.....	40

Figure Contents

Figure 1-1	Fuse Holder.....	8
Figure 1-2	How to remove the handle.....	10
Figure 3-1	Front panel.....	13
Figure 3-2	Real panel.....	14
Figure 3-3	Keypad I.....	14
Figure 3-4	Keypad II.....	15
Figure 3-5	VFD.....	15
Figure 4-1	Connect to DUT.....	17
Figure 6-1	How to insert the cables.....	24
Figure 6-2	Typical Circuit Diagram of Handler Interface Input signals.....	25
Figure 6-3	Typical Circuit Diagram of Handler Interface Output signals.....	25
Figure 6-4	Timing chart.....	25
Figure 7-1	The RS-232 connector in the real panel.....	27
Figure 8-1	Command Tree Example.....	29
Figure 8-2	FUNcTION Command Tree.....	32
Figure 8-3	TRIG Subsystem Tree.....	34
Figure 8-4	BEEPer Subsystem Tree.....	34
Figure 8-5	FETCh? Subsystem Tree.....	35
Figure 8-6	ERRor Subsystem Tree.....	36
Figure 8-7	IDN? Common Command Tree.....	36
Figure 8-8	*RST Common Command Tree.....	36
Figure 8-9	*TRG Subsystem Tree.....	36

Table Contents

Table 3-1	Front panel description.....	13
Table 3-2	Real panel description.....	14
Table 3-3	Keypad I description.....	14
Table 3-4	Keypad II description.....	15
Table 3-5	VFD description.....	15
Table 4-1	Range number, range resistance and range change process (AT520).....	17
Table 5-1	Comparator Output (Resistance/Voltage measurement mode).....	22
Table 5-2	Comparator setting example:.....	22
Table 6-1	Pin assignment.....	23
Table 6-2	Description of Handler Interface Input Signals.....	23
Table 6-3	Comparator Record Selection Truth Table.....	23
Table 6-4	Output Signals.....	24
Table 6-5	Power Signal.....	24
Table 6-6	Timing.....	26
Table 7-1	RS-232 connector pinout.....	27
Table 8-1	Multiplier Mnemonics.....	31
Table 9-1	AT520 Resistance Measurement.....	38
Table 9-2	AT520 Voltage Measurement.....	38
Table 9-3	AT520SE Resistance Measurement.....	38
Table 9-4	AT520SE Voltage Measurement.....	39
Table 9-5	AT520L Resistance Measurement.....	39
Table 9-6	AT520L Voltage Measurement.....	39
Table 9-7	AT520M Resistance Measurement.....	39
Table 9-8	AT520M Voltage Measurement.....	39

1. Unpacking and Preparation

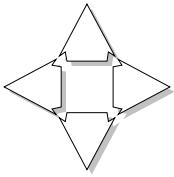

This chapter describes how to set up and start the AT520x AC Milliohm Meter.

- Incoming Inspection
- Power Requirements
- Setting up the Fuse
- How to Remove the Handle
- Environmental Requirements
- Cleaning

1.1 Incoming Inspection

After you receive the instrument, carry out checks during unpacking according to the following procedure.



If the external face of the instrument (such as the cover, front/rear panel, VFD screen, power switch, and port connectors) appears to have been damaged during transport, do not turn on the power switch. Otherwise, you may get an electrical shock.

Check that the packing box or shock-absorbing material used to package the instrument has not been damaged.

Referring to <Packing List> in the packing box, check that all packaged items supplied with the meter have been provided as per the specified optioned.

NOTE

If an abnormality is detected, contact the company and transport the meter to your nearest Applent Instruments sales or service office. For inspection by the transport company, save the packing box, shock-absorbing material, and packaged items as you received them.

1.2 Setting up Fuse

Figure 1-1

Fuse Holder

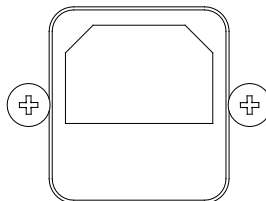

~Line: 90VAC–115VAC
20VA MAX
Fuse: 250V 1A
Slow Blow

Please use the following fuse type.

UL/CSA type, Slow-Blow, 5×20-mm miniature fuse, 1A, 250 V



When you need a fuse, contact your nearest Applent Instruments sales or service office. To verify and replace the fuse, remove the power cable and pull out the fuse holder.

NOTE Two fuses in Fuse Holder.

1.3 Environmental Requirements

Set up the AT520x where the following environmental requirements are satisfied.

Operating Environments

Ensure that the operating environment meets the following requirements.

Temperature: 0°C to 55°C

Temperature range at calibration: 23°C±5°C (<1°C deviation from the temperature when performing calibration)

Humidity: 15% to 85% at wet bulb temperature ≤ 40°C (non-condensation) Altitude: 0 to 2,000m

Vibration: Max. 0.5 G, 5 Hz to 500 Hz

1.4 Cleaning

To prevent electrical shock, disconnect the AT520x power cable from the receptacle before cleaning.

Use a dry cloth or a cloth slightly dipped in water to clean the casing.

Do not attempt to clean the AT520x internally.



WARNING: Don't Use Organic Solvents (such as alcohol or gasoline) to clean the Instrument.

1.5 How to Remove the Handle

A handle kit is attached to the AT520x:

Figure 1-2 **How to remove the handle**

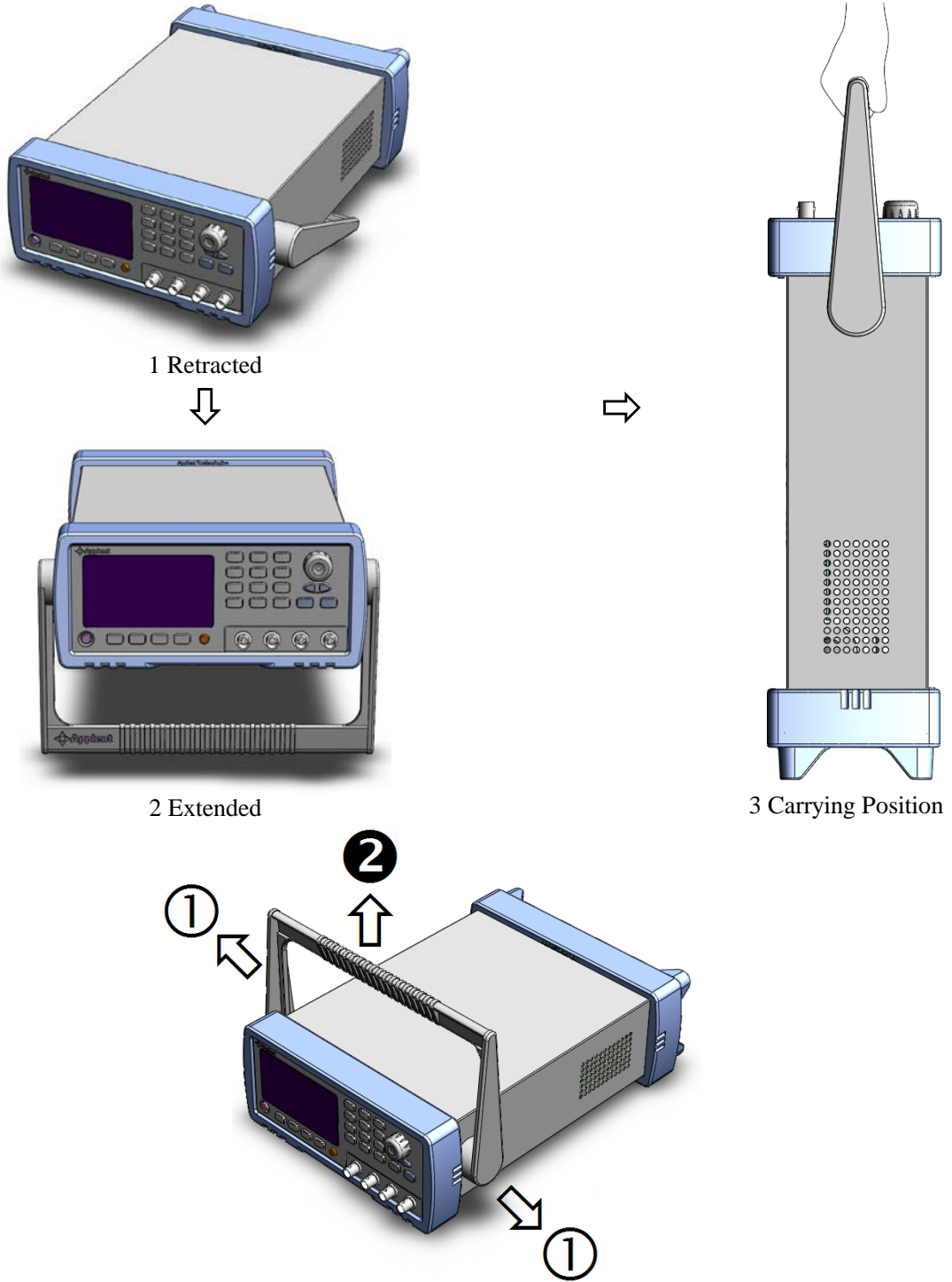

Remove Handle (Lift the handle perpendicular to the unit while pulling it in the direction of 1.)

2. Overview

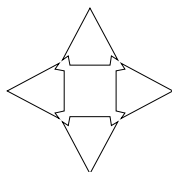

This chapter contains general information about AT520x. The information is organized as follows

- Introduction
- Main Specifications
- Feature overview

2.1 Introduction

Thank you for purchasing AT520x AC Milliohm meter.

The Applet AT520x completes with comparator function and external interface utilizing the principles of the AC 4-terminal method that gives priority to line use and offers high speed, high accuracy and high resolution. External output terminal, external control terminal and RS-232C interface are standard features. The instrument also features an m-Ohm and V mode that allows simultaneous measurement and comparison of battery internal resistance and open-circuit voltage. This Meter is highly suitable for battery inspection lines as one unit can act as both a low-resistance meter and a volt meter.

2.2 Functional Comparison

Model	Resistance Range	Voltage Range	Accuracy
AT520	0.001mΩ-3.2kΩ	0.0001~60.000V	0.3%
AT520SE	0.01mΩ-3.2kΩ	0.001~60.00V	0.5%
AT520L	0.01mΩ-32Ω	0.001~60.00V	0.5%
AT520M	0.01mΩ-32Ω	0.001~100.00V	0.5%

2.3 Main Specifications and Features

Some main specifications of the AT520x include:



Full AT520x specifications are included in Section 7.

Uses 4-terminal measurement method, AT520x is capable of accurate resistance measurements independent of lead resistance or contact resistance generated between the lead and the DUT.

Automatic test range or 7 manual ranges.

20mV peak voltage max (Open-circuit terminal voltage)

High-speed measurement: 20 readers per second.

Dual Display: Resistance and DC Voltage.

Trigger Mode: Internal Trig, Manual Trig, Remote Trig, and External Trig mode.

Battery measurement:

AT520x simultaneously measures resistance and DC voltage, so it is capable of making a combined GD/NG judgment possible for internal resistance and open-circuit voltage.

High brightness VFD

Calibration (Zeroing) Function:
Short zeroing

Comparator Function:
Up to 30 tables of comparator settings and Output HI/IN/LO and GD/NG io signals.

Interface:
Built-in RS232C: Used SCPI with single 3-wire serial interface
Handler (AT520): Output the results of comparator, EOC signal and input the numbers of the compare file, Trigger signal from the PLC.

3. Start up

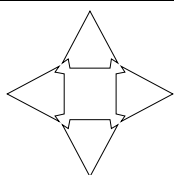

This chapter describes names and functions of the front panel, rear panel, and screen display and provides the basic procedures for operating AT520x.

- Front panel summary
- Rear panel summary
- VFD

3.1 Front panel

Figure 3-1

Front panel

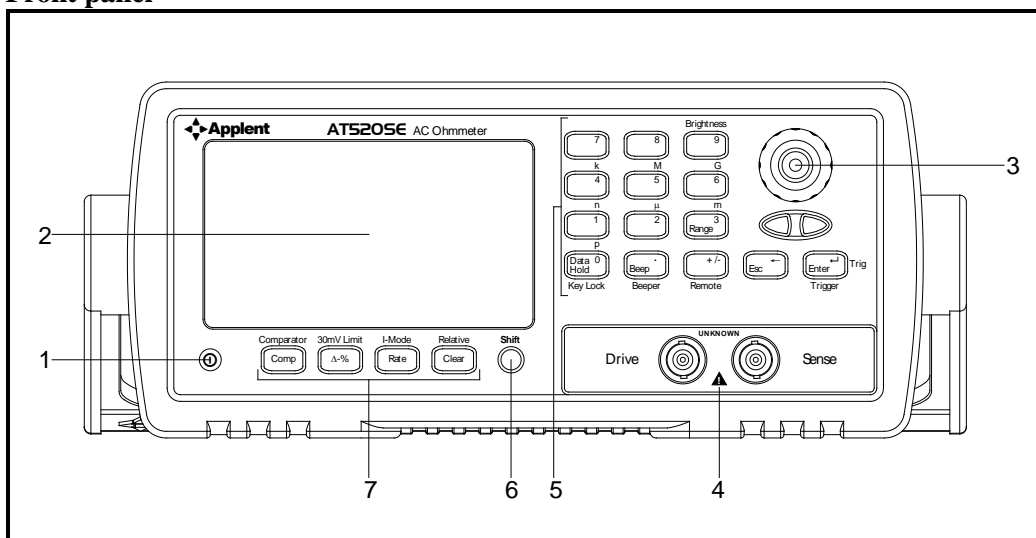

Table 3-1

Front panel description

No.	Name	Description
1	POWER SWITCH	Push down: ON, Push up: OFF
2	VFD	Displays measurement results, instrument status and user's interface menus.
3	Knob	To choose menu item and input number
4	Terminals	The 4-terminal Kelvin chip leads connect to the input terminal
5	Keypad II	Multi-function keys: Numeric, 1 st Function and 2 nd Function.
6	Shift	Key to press before 2 nd Function
7	Keypad I	Dual-Function keys: 1 st Function and 2 nd Function.

3.2 Real panel

Figure 3-2 Real panel

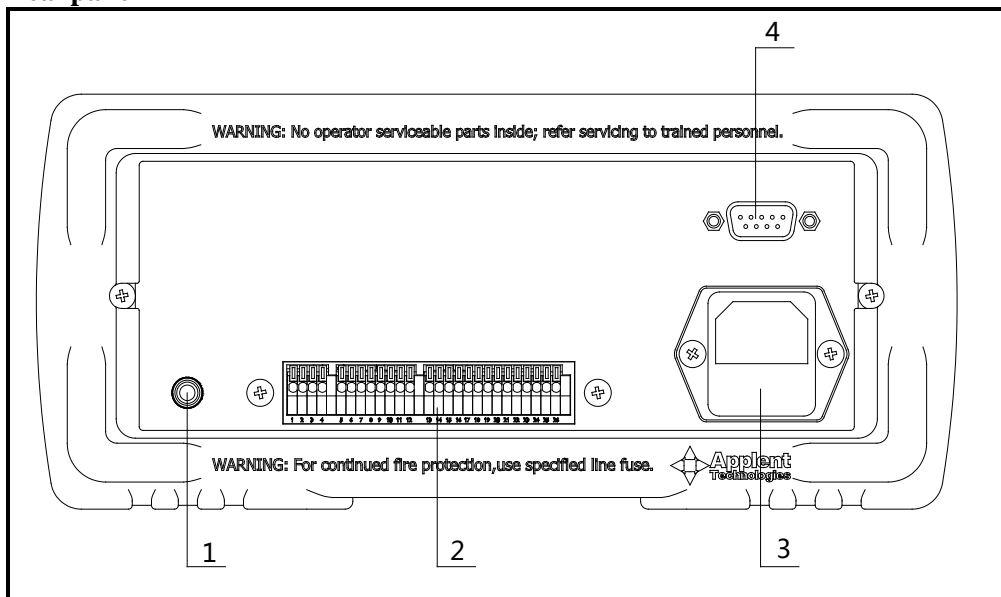

Table 3-2

Real panel description

No.	Name	Description
1	GND	
2	Handler Interface	AT520 only
3	Power Inlet	Built-in fuse type
4	RS-232C Interface	

3.3 Keypad I

Figure 3-3

Keypad I

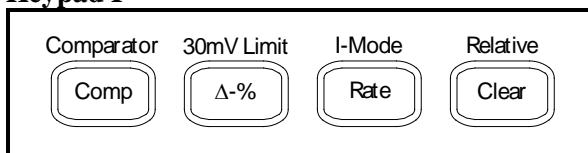

Table 3-3

Keypad I description

No.	Name	Description
1	Comp	Turn ON/OFF Comparator
2	(Shift)Comparator	Setup the comparator
3	Δ-%	Deviation display. Include: Absolute deviation (ΔABS), Deviation display (Δ%), and Comparator bin.
4	(Shift)30mV Limit	Open-circuit terminal voltage limiter: Turn ON/OFF 30mV Limit function
5	Rate	Test rate: Slow/Med/Fast
6	(Shift)I-Mode	Choose the test parameter
7	Clear	Short Correction
8	Relative	Relative zeroing value: The REL indicator lit means the relative value is ON. If the Relative is off, measurement results will not remove the value of short-circuit is cleared.

Figure 3-4

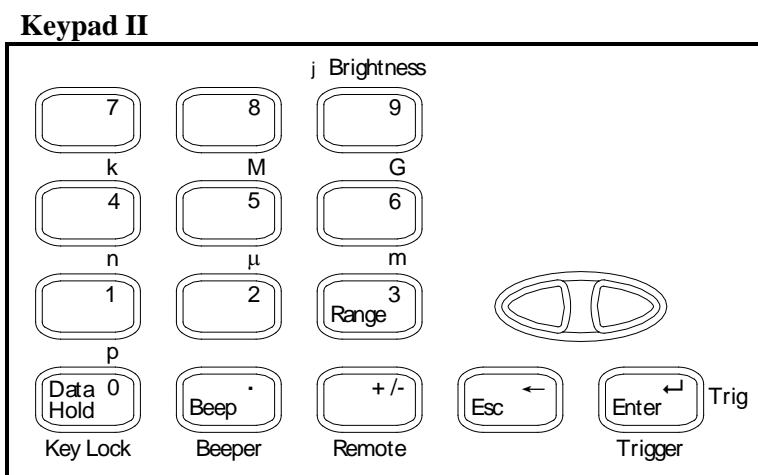

Table 3-4

Keypad II description

No.	Name	Description
1	Data Hold	
2	(Shift)Key Lock	Keypad Locked
3	Beep	Beep ON/OFF
4	(Shift)Beeper	Setup Beep
5	Range	Auto-range ON/OFF
6	(Shift)Remote	Enable RS-232C and setup baud rate.
7	./+/-/0~9	Numeric keys.
7	(Shift)p/n/μ/m/k/M/G	Unit
8	Brightness	Adjust VFD brightness
9	ESC	Exit and back to measurement mode.
10	Enter	Determine settings.

3.4 VFD

Figure 3-5

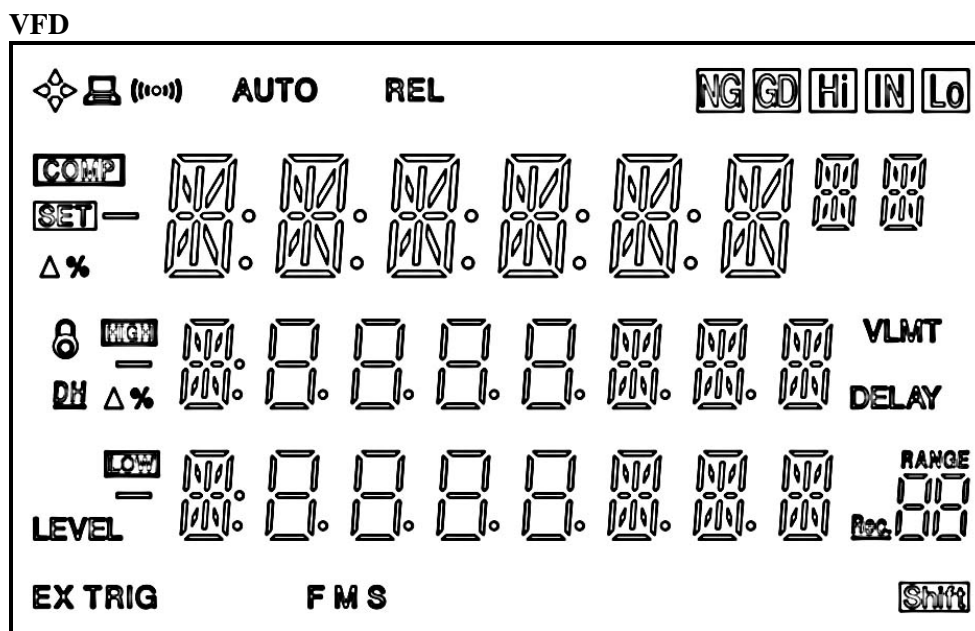





Table 3-5

VFD description

ID	Name	Description (Lit)
◆	Trade Mark	
RS-232C	RS-232C	Remote Interface (RS-232C) ON.

ID	Name	Description (Lit)
	Beep	Beep ON
AUTO	Auto range	Auto ranging enabled
REL	Relative	Relative is ON
NG	Not Good	Voltage Not Good(Fail)
GD	Good	Voltage Good(Pass)
Hi	High(NG)	Resistance beyond the upper limit
IN	In	Resistance Pass
Lo	Low(NG)	Resistance beyond the lower limit
COMP	Comparator	Comparator is ON
SET	Comparator Set	
HIGH	Upper	The upper limits of the comparator
LOW	Lower	The lower limits of the comparator
	Keypad Lock	
<i>DH</i>	Data Hold	
EX	External Trigger	
Trig	Manual Trigger	
F M S	Sampling rate	F: Fast, M:Medium, S:Slow
VLMT	Voltage Limit	Open-circuit terminal voltage is limited to 20mV
	Range No. Record No.	
Shift	Shift	Shifted to the 2 nd Function

3.5 Power On/Off

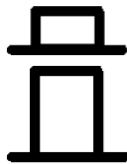

Power On



Power Off

3.5.1 Warm-up Time

AT520x is ready to be used as soon as the power-up sequence has completed. However, to achieve the accuracy rating, warm up the instrument for 30 minutes.

4. Configuration

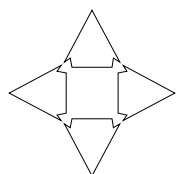

This chapter describes how to configure AT520x. Include:

- Connect to Device under Test (DUT)
- Setting the measurement range
- Sampling Rate
- Clear zero correction (Zero adjust)
- Relative value
- Voltage Limiter
- Let beep on/off
- Deviation Display Mode
- Lock out the keypad

4.1 Connect to Device under Test (DUT)

Figure 4-1

Connect to DUT

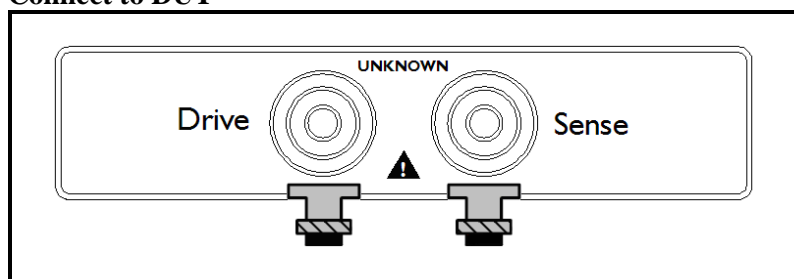

Be sure to ensure the floating state for a battery circuit with voltage exceeding 60VDC.

4.2 Setting the Measurement Range

For any measurement range, the maximum accuracy is obtained when the measured impedance is close to the full-scale value of the measurement range being used. Conversely, if the measured impedance is much lower than the full-scale value of measurement range being used, the measurement accuracy will be reduced. This sometimes cause a discontinuity occurs in the measurement values at the measurement range boundaries. If measurement range is set to Auto range, the impedance curve will skip when impedance range change occurs. To prevent this from occurring, the impedance range should be set to the Hold range mode.

Use the LEFT, RIGHT and AUTO keys to select the desired range. Press the Range key to select auto-range.

Table 4-1

Range number, range resistance and range change process (AT520)

No.	Range Resistance	Range up	Range down
1	10mΩ	↓ 31mΩ	↑ 30mΩ
2	100mΩ	↓ 310mΩ	↑ 300mΩ
3	1Ω	↓ 3.1Ω	↑ 3Ω
4	10Ω	↓ 31Ω	↑ 30Ω
5	100Ω	↓ 310Ω	↑ 300Ω
6	1kΩ	↓	↑

Press **Shift** + **Range** to select the voltage range (AT520/AT520SE/AT520L).

No.	Range	Maximum indication	Resolution
1	6V	±6.0000V	100μV
2	60V	±60.000V	1mV

AT520M

No.	Range	Maximum indication	Resolution
1	10V	±10.000V	1mV
2	100V	±100.00V	10mV

Note

1. When auto-range is selected, both resistance and voltage ranges are set to auto-range mode.
2. If the range is not determined in auto-range mode, perform a zero-adjust.

4.3 Setting the Sampling Rate

The RATE operation sets the integration time of the A/D converter, the period of time the input signal is measured (also known as aperture). The integration time affects the usable digits and the amount of reading noise.

The RATE items are explained as follows, you can press **Rate** key to choose.

Fast: 20 readings/s. Use FAST if speed is of primary importance, at the expense of increased reading noise and fewer usable digits.

Medium: 6 readings/s. Use Medium when a compromise between noise performance and speed is acceptable.

Slow: 1 readings/s. SLOW provides better noise performance at the expense of speed.

4.4 Short Clear Zero Correction

The SHORT correction function reduces the measurement error due to the residual impedance existing between the UNKNOWN terminals and the DUT.

Step1: Under measurement mode, connect the leads as shown below:

Right connection:

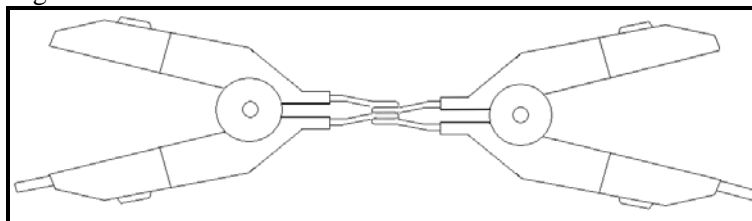

Wrong connection:

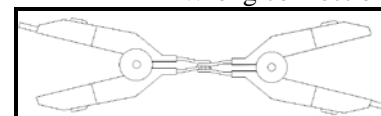

Step2: Press **Clear** Key when the value observed in the VFD stabilizes.

Step3: After Clear Zero Correction, AT520x returns to measurement mode.

4.5 Choose Measure Parameter (AT520)

Step1: Under measurement mode, Press **Shift** Key. "Shift" appears lit on the VFD.

Step2: Press **Rate** (I-Mode) key.

Step3: To switch measure parameter as below:

R-θ

X-θ

Z-0
L-0

4.6 Relative value

Relative value is a function used to return the clear-Zero value to their default value.

- Step1: Under measurement mode, Press **[Shift]** Key. “Shift” appears lit on the VFD.
- Step2: Press **[Clear]** (Relative) key. “REL” disappears.
- Step3: The clear-zero value in full resistance and voltage ranges are returned to their default values.

4.7 Voltage Limiter

The voltage limiter may be set. If it is set, the open-circle voltage applied to the DUT is limited to a maximum of 30mVpeak (typical 20mVpeak). This protects the oxide film on the contact surface of the DUT. If you use AT520x to test battery, keep voltage limiter OFF.

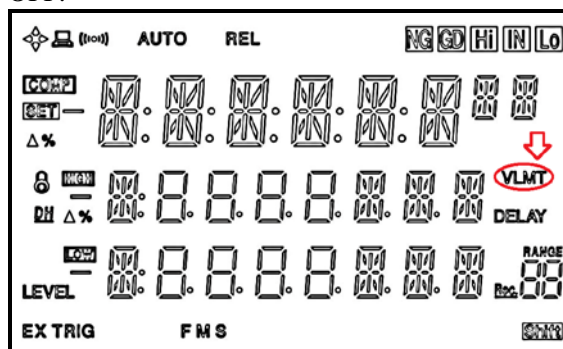

- Step1: Under measurement mode, Press **[Shift]** Key. “Shift” appears lit on the VFD.
- Step2: Press **[Δ-%]** (30mV Limit) key. “VLMT” appears lit.

4.8 Set beep ON/OFF

When the beep is set to ON, the buzzer can be set to sound according to the result of the comparator operation.

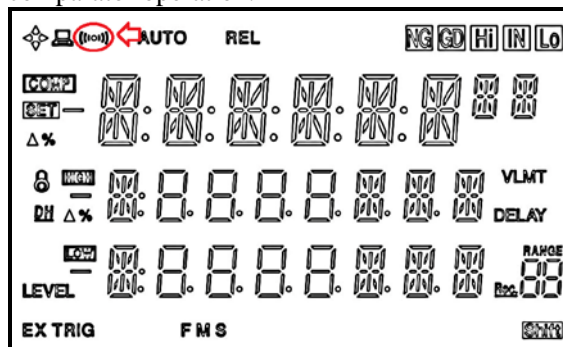

- Step1: Under measurement mode
- Step2: Press **[Beep]** key. “((000))” appears lit.

4.9 Deviation Display Mode

- Step1: Under measurement mode
- Step2: Press **[Δ-%]** key to select items as below
 - Δ Absolute deviation

$\Delta\%$ Deviation display
High/In/Low The results of comparator
Step3: The VFD no.2 line will display the deviation value.

$$\Delta\text{ABS} = \text{Measurement Value} - \text{Nominal Value}$$
$$\Delta\% = \Delta\text{ABS} / \text{Nominal Value} * 100$$

4.10 Lock out the keypad

Step1: Under measurement mode
Step2: Press **Shift** **Key Lock** key to lock/unlocked the keypad.
Step3: The VFD no.2 line will display the deviation value.

 indicator lit means the keypad is locked.

5. Comparator

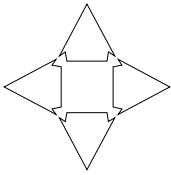

This chapter describes how to configure AT520x comparator.

Include:

- Turn ON/OFF Comparator
- Setup the comparator record number
- Setup Comparator

5.1 Turn ON/OFF the Comparator

- Step1: Under measurement mode
- Step2: Press **Comp** key to toggles the comparator ON and OFF.
 “COMP” appears lit on the VFD when the comparator is on.
 “COMP” is not lit, the comparator function does not execute.

5.2 Setup the record number and comparator

- Step1: Press **Shift** **Comparator** to the setup comparator.
- Step2: **Rec.09** indicator at the lower right corner of screen flashes means you can setup record number.



- Step3: Press **Left** or **Knob** to choose the record number from 1 to 30.
- Step4: You can
- a) Press **Enter** key to enter the comparator state to setup nominal value and limit value.
 - b) Or press **Esc** to exit from comparator setup and the record number is stored.
- Step5: Press **Shift** **Comparator** to setup comparator.
- Step6: Press **Right** or **knob** to choose the resistance’s nominal value (1st line), upper limit value (2nd line), lower limit (3rd line).
- Step7: Press digits to input value
- Step8: Press **Enter** or **Shift** + n/μ/m/k/M/G to key in the unit.
 Note: Enter stand for x1 unit.
- Step9: Press **Right** or **knob** again to choose next voltage setup page
- Step10: Input number and key in the unit
- Step11: Press **ESC** to end setup.

5.3 Setup Beeper

- Step1: Press **Shift** **Comparator** to enter Beeper setup window.
- Step2: Press **Left** key or Turn Knob to choose following items:
- | | |
|----|------------------|
| GD | Beep while pass. |
| NG | Beep while fail. |

- Step3: Press **Enter** key to exit with setting value saved.
 Press **ESC** key to exit without being saved.

5.4 How the comparator work

When comparator is ON,

Resistance:

Limit Lower < Rx/< Limit Upper IN
 Rx ≤ Limit Lower LO
 Rx ≥ Limit Upper HI

Table 5-1

Comparator Output (Resistance/Voltage measurement mode)

Resistance \ Voltage	Hi	IN	Lo
Hi	NG	NG	NG
IN	NG	GD	NG
Lo	NG	NG	NG

Table 5-2

Comparator setting example:

Resistance Nominal Value	Upper Limit	Lower Limit
100 mΩ	120 mΩ	80 mΩ
Voltage Nominal Value	Upper Limit	Lower Limit
1.5 V	1.52 V	1.48 V

Accordance with the above settings to test a battery, the measured results of resistance: 100 mΩ , voltage 1.40 V, then sorting the results of its output is "NG IN".

Accordance with the above settings to test a battery, the measured results of resistance: 100 mΩ , voltage 1.51 V, then sorting the results of its output is "GD IN".

Accordance with the above settings to test a battery, the measured results of resistance: 150 mΩ , voltage 1.51 V, then sorting the results of its output is "NG Hi".

Accordance with the above settings to test a battery, the measured results of resistance: 60 mΩ , voltage 1.50 V, then sorting the results of its output is "NG Lo".

6. Handler Interface (AT520)

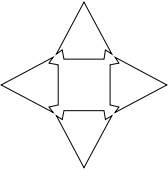

This chapter describes how to use the handler interface.

- Pin Assignment
- Circuit Diagram
- Timing Chart

By using the handler interface, you can output the measurement completion signal (EOC), the screening result of the comparator function (GD/NG/HI/IN/LO), and so on to external devices from the AT520. You can also input the external trigger signal and the comparator select signal to the AT520. With this interface and the comparator function, you can build an automatic screening system composed of the AT520 and the handler.

6.1 Pin Assignment

Table 6-1

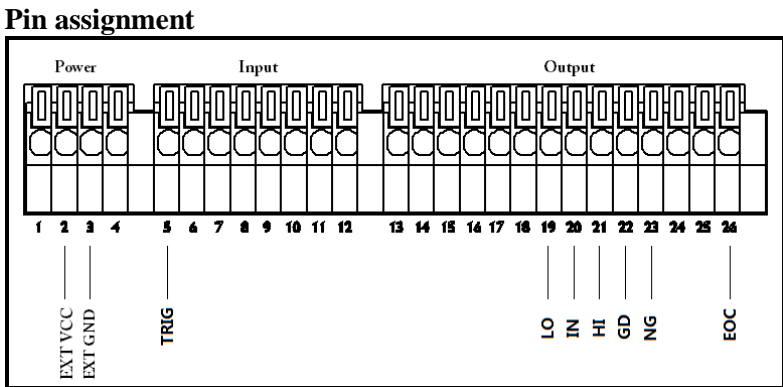

Table 6-2

Description of Handler Interface Input Signals

5	TRIG	External Trigger Signal (Rising edge)
8	COMP.4	Comparator Record Selector. (1 thru 30) See Table 6-3
9	COMP.3	
10	COMP.2	
11	COMP.1	
12	COMP.0	

Table 6-3

Comparator Record Selection Truth Table

COMP 4-0	Record	COMP 4-0	Record	COMP 4-0	Record	COMP 4-0	Record
11111	No change	10111	8	01111	16	00111	24
11110	1	10110	9	01110	17aa	00110	25
11101	2	10101	10	01101	18	00101	26
11100	3	10100	11	01100	19	00100	27
11011	4	10011	12	01011	20	00011	28
11010	5	10010	13	01010	21	00010	29
11001	6	10001	14	01001	22	00001	30
11000	7	10000	15	01000	23	00000	No change

Table 6-4**Output Signals**

19	Lo	Resistance lower signal.(Low)
20	IN	Resistance Pass.(Low)
21	Hi	Resistance upper signal.(Low)
22	GD	Pass signal. (Low)
23	NG	Fail signal. (Low)
26	EOC	Measurement completion signal. (Low)

Table 6-5**Power Signal**

2	EX-VCC	External VCC (5~35VDC)
3	EX-GND	External GND

6.2 Connection method

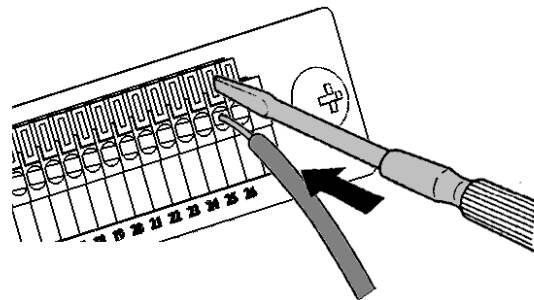
Figure 6-1**How to insert the cables**

- Step1: Push down the button with an appropriate tool, such as a flathead screw driver
 Step2: With the button pushed down, insert the cables into the holes
 Step3: Release the button and the cables secured.

Recommended wire: Single strand 0.65mm dia.(AWG #22)
 Multi-strand 0.32 mm². (AWG #22)

Usable limits: Single strand 0.32 to 0.65mm dia.
 Multi-strand 0.08 to 0.32mm².

Standard insulation stripping length: 10mm

Button pressing tool: Blade screwdriver (shaft diameter $\phi 3$, tip width 2.6mm)



- To prevent damage to the handler, avoid applying voltage or current exceeding the rated value.
- In order to avoid electric shock, turn off the instrument power before plugging in or plugging any of the interface connectors.
- AT520 handler output signal CAN NOT drive relay. If you need to connect a relay, use external transistor to drive.
- Avoid short-circuiting the external output and control terminals.

6.3 Power Rating

	Input/Output device	Logic	Electrical requirements
OUTPUT	Corrector out with pull-up resistance	Negative logic	35VDC 50mADC max
INPUT		Negative logic	50mADC max
EXT.DCV	DC voltage input		35VDC max

6.4 Electrical Characteristics

6.4.1 Input Signal:

Each input signal is connected to the LED (cathode side) of the photo-coupler. The LED (anode side) is connected to the pull-up power supply voltage.

6.4.2 Output Signal:

Each output signal is outputted via an open collector by using a photo-coupler. The voltage of each output is obtained by connecting pull-up resistors, inside or outside of the AT520.

6.4.3 Power supply

The power supply for the judgment output signal pull-up and that for the operation output signal pull-up and input signal drive can be set separately. You can select from +3.3V to +35V external power supply.

Figure 6-2 Typical Circuit Diagram of Handler Interface Input signals.

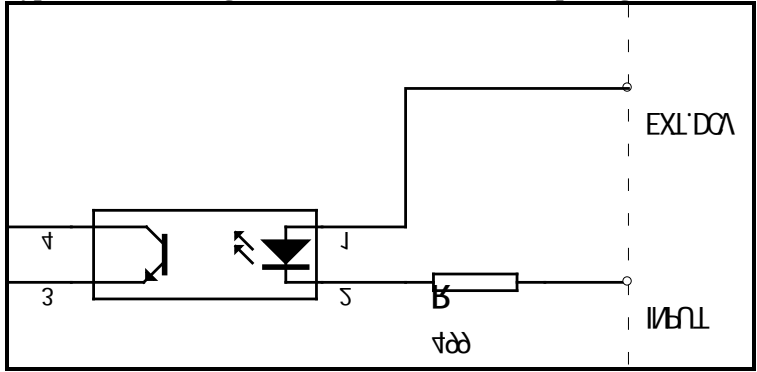
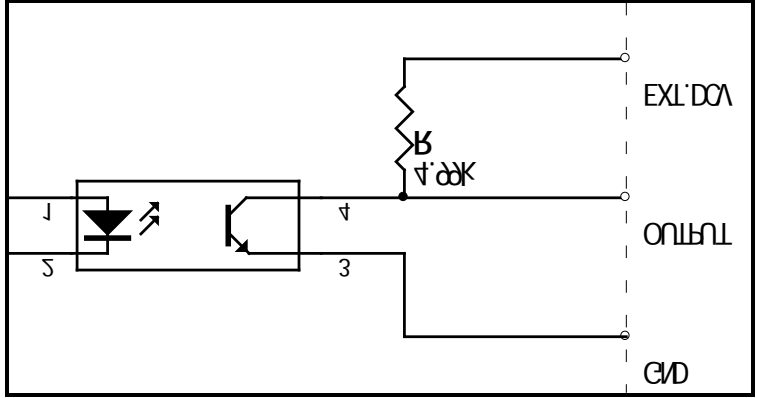

Figure 6-3 Typical Circuit Diagram of Handler Interface Output signals.



6.5 Timing Chart

Figure 6-4 Timing chart

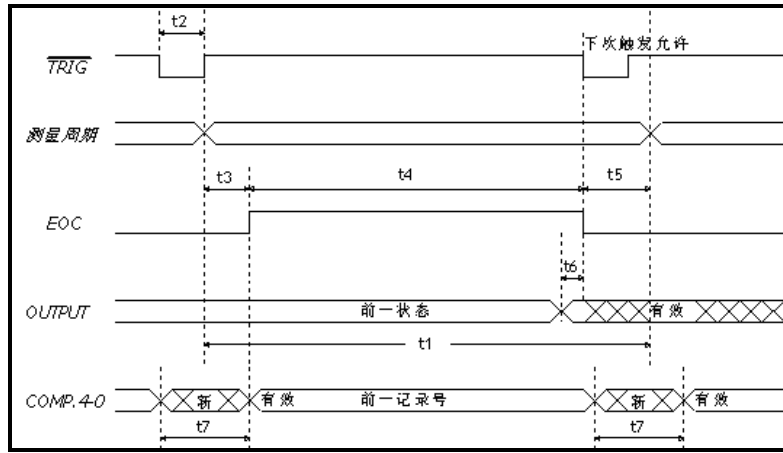
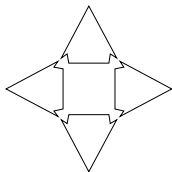

Table 6-6 Timing

	Description	Time			
		MIN	TYP	MAX	
t1	One Measurement Circle	FAST	52ms	54ms	56ms
		MEDIUM	193ms	195ms	197ms
		SLOW	1.05s	1.065s	1.07s
t2	Trig pulse width		1ms	-	
t3	Trig Delay Time	-	25 μ s		
t4	AD Time (EOC[BUSY])	FAST	44ms	46ms	48ms
		MEDIUM	186ms	188ms	190ms
		SLOW	1.05s	1.056s	1.07s
t5	Print Result Time	7ms	8ms	9ms	
t6	Handler Out to EOC Time	-	10 μ s	-	
t7	Comparator input signal hold time		1ms	-	

7. Remote Control



This chapter provides the following information to remotely control the AT520x via the RS-232C interface.

- About RS-232C
- RS-232C operation.
- About SCPI

AT520x can use the RS-232 interface to communicate with the computer to complete all the instrument functions.

7.1 About RS-232C

You can connect a controller (i.e. PC and PLC) to the RS-232 interface using Applent RS-232 DB-9 cable. The serial port uses the transmit (TXD), receive (RXD) and signal ground (GND) lines of the RS-232 standard. It does not use the hardware handshaking lines CTS and RTS.



NOTE:

JUST ONLY Use an Applent (not null modem) DB-9 cable.
Cable length should not exceed 2m.

Figure 7-1 The RS-232 connector in the real panel

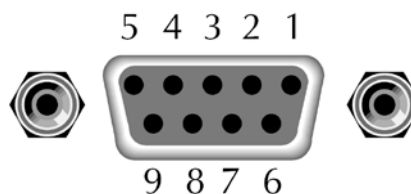

Table 7-1 RS-232 connector pinout

NAME	DB-25	DB-9	NOTE
DCD	8	1	Not Connection
RXD	3	2	Transmit data
TXD	2	3	Receive date
DTR	20	4	Not Connection
GND	7	5	Ground
DSR	6	6	Not Connection
RTS	4	7	Not Connection
CTS	5	8	Not Connection

■ Make sure the controller you connect to AT520x also uses these settings.

The RS-232 interface transfers data using:

- 8 data bits,
- 1 stop bit,
- And no parity.

7.2 Enable RS-232C Interface and select baud rate

To enable RS-232 interface, do the following:

- Step1: Press **Shift** **Remote** to enter remote setup window.
- Step2: Press **Left/Right** key or rotate knob to choose following items:
OFF RS-232C disabled.
RS232 RS-232C interface enabled.
- Step3: If RS232 item selected, Press **Enter** key to set baud rate.

- Step4: Rotate knob to choose 4800 / 9600/12800/19200/ 38400/ 57600
- Steip5: Confirm your selection by pressing ENTER

7.3 SCPI Language

Standard Commands for Programmable Instruments (SCPI) is fully supported by the RS-232 interfaces.



NOTE:
AT520x ONLY supports the SCPI Language.

8. Command Reference

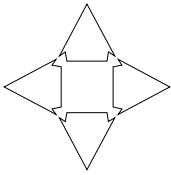

This chapter contains reference information on programming AT520x with the SCPI commands.

This chapter provides descriptions of all the AT520x's available RS-232 commands which correspond to Standard Commands for Programmable Instruments (SCPI) command sets, listed in functional subsystem order.

8.1 Terminator

NL : The EOI line is asserted by New Line or ASCII Line Feed character (decimal 10, Hex 0x0A , or ASCII '\n')

8.2 Notation Conventions and Definitions

The following conventions and definitions are used in this chapter to describe RS-232 operation.

< > Angular brackets enclose words or characters that are used to symbolize a program code parameter or an RS-232 command.

[] A square bracket indicates that the enclosed items are optional.

\n Command Terminator

8.3 Command Structure

The AT520x commands are divided into two types: Common commands and SCPI commands.

The common commands are defined in IEEE std. 488.2-1987, and these commands are common for all devices. The SCPI commands are used to control all of the AT520/A520SE's functions.

The SCPI commands are tree structured three levels deep. The highest level commands are called the subsystem commands in this manual. So the lower level commands are legal only when the subsystem commands have been selected.

A colon (:) is used to separate the higher level commands and the lower level commands.

Semicolon (;) A semicolon does not change the current path but separates two commands in the same message.

Figure 8-1

Command Tree Example

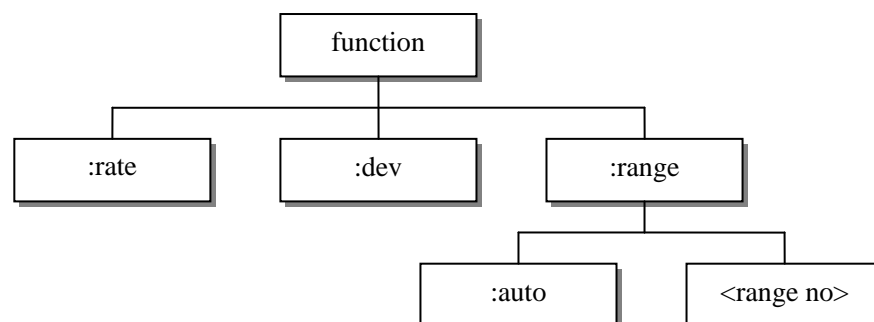

Example:

```
function:range:auto on
function Subsystem Command
  range Level 2
    auto Level 3
      on Parameter
```

- The basic rules of the command tree are as follows.
 - Letter case (upper and lower) is ignored.
For example,
FUNCTION:RANGE = function:range
 - Spaces (_ used to indicate a space) must not be placed before and/or after the colon (:).
For example,
 function _:range → **function:range**
 - The command can be completely spelled out or in abbreviated.(The rules for command abbreviation are described later in this section)
For example,
function:range = func:rang
 - The command header should be followed by a question mark (?) to generate a query for that command.
For example,
function:range?
 - The semicolon (;) can be used as a separator to execute multiple commands on a single line. The multiple command rules are as follows.
Commands at the same level and in the same subsystem command group can be separated by a semicolon (;) on a multiple command line.
For example,
beep:vol larg;bin good
To restart commands from the highest level, a semicolon (;) must be used as the separator, and then a leading colon (:), which shows that the restarted command is a command at the top of the command tree, must follow.
For example,
func:rang 5;[:beep:bin good
 - The common commands can restart only after a semicolon on a multiple command line.
For example,
func:rang 8;*IDN?;auto on
 - Command abbreviations:
 - Every command and character parameter has at least two forms, a short form and a long form. In some cases they will be the same. The short form is obtained using the following rules.
 - A) If the long form has four characters or less, the long form and short form are the same.
 - B) If the long form has more than 4 characters:
 - (a) If the 4th character is a vowel, the short form is the first 3 characters of the long form.
For example:

comparator	abbr. to	comp
current	abbr. to	curr
range	abbr. to	rang
 - (b) If the 4th character is not a vowel, the short form is the first 4 characters.
For example:

resistance	abbr. to	res
volume	abbr. to	vol
 - If the long form mnemonic is defined as a phrase rather than a single word, then the long form mnemonic is the first character of the first word(s) followed by the entire last word. The above rules, when the long form mnemonic is a

single word, are then applied to the resulting long form mnemonic to obtain the short form.

For example:

PercentTolerance abbr. to ptol



The AT520x accepts the three forms of the same SCPI commands: all upper case, all lower case, and mixed upper and lower case.

8.4 Header and Parameters

The commands consist of a command header and parameters. (See the following.)

For example

comp:nom 100.0e3
Header Parameter

- Headers can be of the long form or the short form. The long form allows easier understanding of the program code and the short form allows more efficient use of the computer.
- Parameters may be of two types as follows.
 - (A) Character Data and String Data Character data consists of ASCII characters. The abbreviation rules are the same as the rules for command headers.
 - (B) Numeric Data
 - (a) interger: For example, 1,+123,-123
 - (b) fix float: For example, 1.23,+1.23,-1.23
 - (c) floating point: For example, 1.23e3, 5.67e-3, 123k, 1.23M, 2.34G,

The available range for numeric data is 9.9E37. When numeric data is used as a parameter, the suffix multiplier mnemonics and suffix units (The suffix multiplier must be used with the suffix unit.) can be used for some commands as follows.

Table 8-1

Multiplier Mnemonics

Definition	Mnemonic
1E18 (EXA)	EX
1E15 (PETA)	PE
1E12 (TERA)	T
1E9 (GIGA)	G
1E6 (MEGA)	MA
1E3 (KILO)	K
1E-3 (MILLI)	M
1E-6 (MICRO)	U
1E-9 (NANO)	N
1E-12 (PICO)	P
1E-15 (PEMTO)	F
1E-18 (ATTO)	A

8.5 Command Reference

All commands in this reference are fully explained and listed in the following functional command order.

- FUNCTION
- TRIG
- BEEPer
- FETCh?
- ERRor

Common Command:

- IDN?
- RST
- TRG

The explanation of each subsystem command is patterned as follows.

1. Subsystem command name

2. Command Tree (Subsystem command only)
3. Compound Command Name
4. Command Description
5. Command Syntax
6. Example Using the Above Command Syntax
7. Query Syntax
8. Query Response
9. Example Using the Above Query Syntax
10. Constraints

8.6 FUNCTION Subsystem

The **FUNCTION** subsystem command group sets the measurement parameter and measurement range.

Figure 8-2 FUNCTION Command Tree

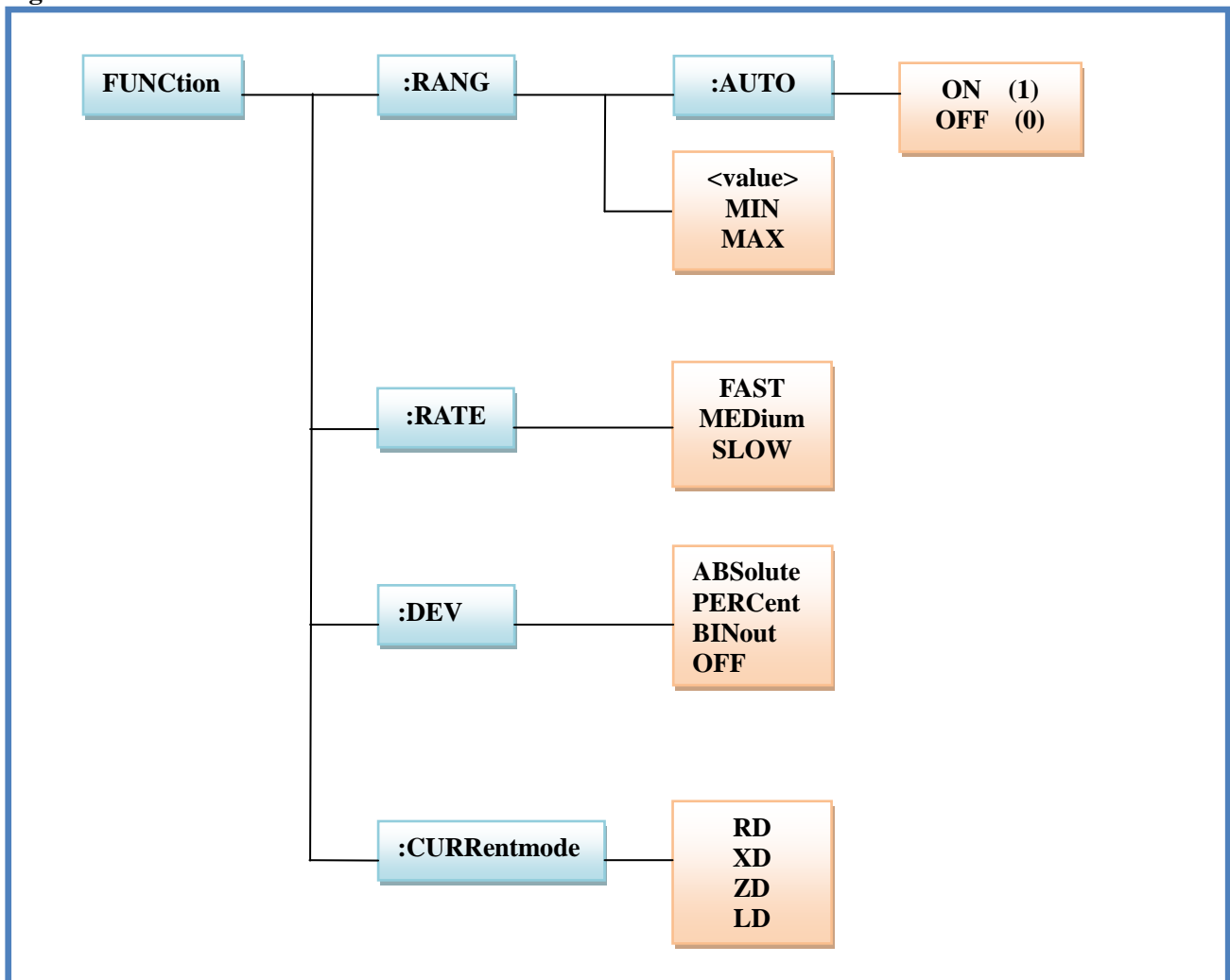

8.6.1 :RANGe:AUTO

The **RANGe:AUTO** command sets the auto range to ON or OFF.

Command Syntax `FUNCTION:RANGe:AUTO {ON,OFF,1,0}`

Parameters {ON,OFF,1,0}

where,

1 : =ON , ASCII(decimal 49) ,

0 : =OFF , ASCII(decimal 48)

For example : `Tx> func:rang:auto off //The auto range will set to manual.`

Query Syntax	FUNCTION:RANGE:AUTO?
Query Response	{on,off}
<i>For example :</i>	Tx> func:rang:auto? Rx> off
Constraints	none

8.6.2 :RANGe

The **:RANGe** command sets the measurement range.

Command Syntax	FUNCTION:RANGe {<integer>,MIN,MAX}
Parameters	{<integer>,MIN,MAX}

where ,

<interger> Range no from 1 to 6.

MIN =1

MAX =6

For example : **Tx>** func:rang 5 //set range to 5
Tx> func:rang min //set range to 1
Tx> func:rang max //set range to 7

Query Syntax	FUNCTION:RANGe?
---------------------	------------------------

Query Response	<integer> Range no from 1 to 6.
-----------------------	---------------------------------

For example : **Tx>** func:rang?
Rx> 6

Constraints	none
--------------------	------

8.6.3 :RATE

The **:RATE** command sets the convert time of the ADC.

Command Syntax	FUNCTION:RATE {slow,medium(med),fast}
Parameters	{slow,medium(med),fast}

For example : **Tx>** RATE fast

Query Syntax	RATE?
---------------------	--------------

Query Response	{slow,medium,fast}
-----------------------	--------------------

For example : **Tx>** RATE?
Rx> fast

Constraints	none
--------------------	------

8.6.4 :DEV

The **:DEV** command sets deviation display mode. The deviation display at No.2 Line of the VFD.

Command Syntax	FUNCTION:DEV { ABSolute, PERCent, BINout, OFF}
Parameters	{ ABSolute, PERCent, BINout, OFF}

For example : **Tx>** func:dev off //The deviation will set to OFF

Query Syntax	FUNCTION:DEV?
---------------------	----------------------

Query Response	{ ABSolute, PERCent, BINout, OFF}
-----------------------	-----------------------------------

For example : **Tx>** func:dev?
Rx> off

Constraints	none
--------------------	------

8.6.5 :CURRentmode

The **:CURRentmode** command sets measure parameter.

Command Syntax	FUNCTION:CURRentmode { RD, XD, ZD, LD}
Parameters	{ RD, XD, ZD, LD}

For example : **Tx>** func:curr rd //R-θ

Query Syntax	FUNCTION:CURRentmode?
---------------------	------------------------------

Query Response	{ RD, XD, ZD, LD }
<i>For example :</i>	Tx> func:curr? Rx> rd
Constraints	none

8.7 TRIG Subsystem

The **TRIG** subsystem command group is used to enable a measurement and to set the trigger mode.

Figure 8-3 TRIG Subsystem Tree

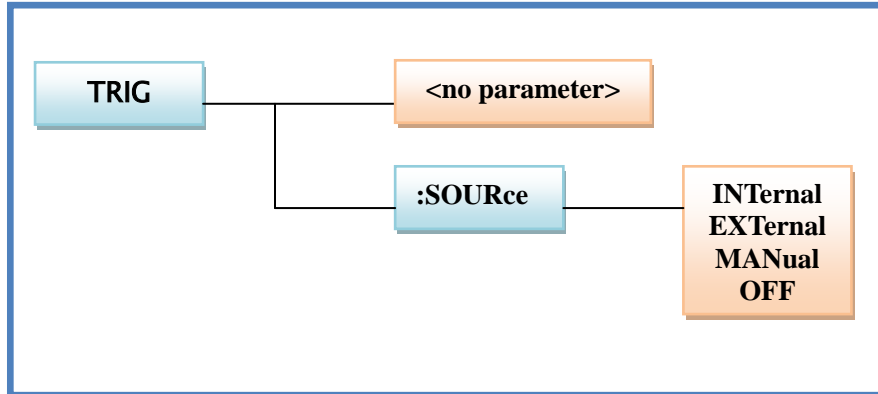

Command Syntax	TRIG
Parameters	None
<i>For example :</i>	Tx> TRIG
Query Syntax	none
Constraints	The trigger source should be set to manual.

8.7.1 :SOURce

The **:SOURce** command sets the trigger mode.

Command Syntax	TRIG:SOURce { internal(int) , manual(man) , external(ext) }
Parameters	{ internal(int) , manual(man) , external(ext) }
<i>For example :</i>	Tx> TRIG:SOUR man
Query Syntax	TRIGger:SOURce?
Query Response	{ internal(int) , manual(man) , external(ext) }
<i>For example :</i>	Tx> TRIG:SOUR? Rx> manual
Constraints	none

8.8 BEEPer Subsystem

The **BEEP** subsystem command group set beep to ON or OFF and sets bin mode to GD or NG.

Figure 8-4 BEEPer Subsystem Tree

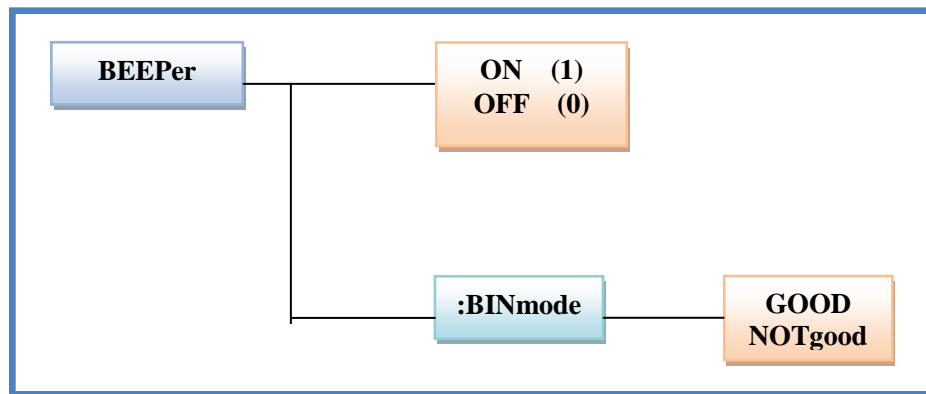

The **:BEEPer** command set beep to ON or OFF.

Command Syntax **BEEPer** {on(1),off(0)}

Parameters {on(1),off(0)}

For example : **Tx>** beep on

Query Syntax **BEEPer?**

Query Response {on,off}

For example : **Tx>** beep?

Rx> on

Constraints None

8.8.1 :BINmode

The **:BINmode** command sets bin mode to GD or NG.

Command Syntax **BEEPer:BINmode** {good,notgood(not)}

Parameters {good,notgood(not)}

For example : **Tx>** beep:bin good

Query Syntax **BEEPer:BINmode?**

Query Response {good,notgood}

For example : **Tx>** beep:bin?

Rx> good

Constraints None

8.9 FETCh Subsystem

The **FETCh?** subsystem command group is a sensor-only command which retrieves the measurement data taken by measurement(s) initiated by a trigger

Figure 8-5 **FETCh? Subsystem Tree**



Query Syntax **FETCh?**

Query Response <float>, <float>
<float> floating point Rx
<float> floating point Vx

For example : **Tx>** FETCh?

Rx> 1.0000e+1,1.5000e+1

Constraints None

8.10 ERRor Subsystem

The ERRor subsystem sets or retrieves last error information.

Figure 8-6 ERRor Subsystem Tree



Query Syntax	ERRor?
Query Response	no error.
For example :	Tx> ERR? Rx> no error
Constraints	None

8.11 *IDN? Common Command

The *IDN? query returns AT520x Version.

Figure 8-7 IDN? Common Command Tree



Query Syntax	*IDN?
Query Response	<model>, <version>
For example :	Tx> *IDN? Rx> AT520 , V2.00

8.12 *RST Common Command

*RST restarts instrument.

Figure 8-8 *RST Common Command Tree

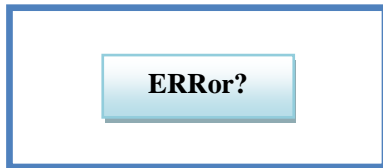

Command Syntax	*RST
Parameters	none
For example :	Tx> *RST Rx> Wait for 3s...
Query Syntax	none
Constraints	none

8.13 *TRG Common Command

The *TRG common command is used to enable a measurement and fetch the test value.
*TRG = TRIG;:FETC

Figure 8-9 *TRG Subsystem Tree



Command Syntax	*TRG
Parameters	None
Query Response	<float>, <float> Where: <float> Rx <float> Vx
<i>For example :</i>	Tx> TRG Rx> 1.0000e+1, 1.5000e+1

9. Specification

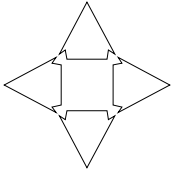

This chapter describes the specifications and supplemental performance characteristics of the AT520/520SE/AT520L/AT520M :

- Specifications
- Dimension

Accuracy is defined as meeting all of the following conditions.

Temperature: 23°C±5°C

Humidity: ≤65% R.H.

Zeroing: Short Correction

Warm up time is 30 min or more.

Rate: Slow

A 1-year calibration cycle

Sampling rate : Fast : 20 times/s

Medium : 5 times/s

Slow : 1 times/s

Test Current Accuracy: 1%

Test Current Frequency Accuracy : 1kHz±0.1Hz

9.1 AT520 Specification

Table 9-1 AT520 Resistance Measurement

Range		Maximum display value	Resolution	Fast	Medium	Slow	Meas. current
1	10mΩ	32.000mΩ	1μΩ	0.5%rdg+6dgt	0.3%rdg+4dgt	0.3%rdg +3dgt	9mA
2	100mΩ	320.00mΩ	10μΩ	0.5%rdg+6dgt	0.3%rdg+4dgt	0.3%rdg +2dgt	1mA
3	1Ω	3.2000Ω	100μΩ	0.5%rdg+6dgt	0.3%rdg +4dgt	0.3%rdg +2dgt	100μA
4	10Ω	32.000Ω	1mΩ	0.5%rdg+6dgt	0.3%rdg +4dgt	0.3%rdg +2dgt	10μA
5	100Ω	320.00Ω	10mΩ	0.5%rdg+6dgt	0.3%rdg +4dgt	0.3%rdg +2dgt	5μA
6	1kΩ	3.2000kΩ	100mΩ	0.5%rdg+6dgt	0.3%rdg +4dgt	0.3%rdg +2dgt	1.5μA
Open-circle voltage		24mV peak max.(when limiter is ON)					

Table 9-2 AT520 Voltage Measurement

Range		Maximum display value	Resolution	Fast	Medium	Slow
1	6V	6.000V	1mV	0.05%rdg+6dgt	0.05%rdg+4dgt	0.05%rdg+2dgt
2	60V	60.00V	10mV	0.05%rdg+6dgt	0.05%rdg+4dgt	0.05%rdg+2dgt

9.2 AT520SE Specification

Table 9-3 AT520SE Resistance Measurement

Range		Maximum display value	Resolution	Fast	Medium	Slow	Meas. current
1	10mΩ	32.000mΩ	10μΩ	1%rdg+6dgt	0.5%rdg+4dgt	0.5%rdg +3dgt	9mA
2	100mΩ	320.00mΩ	100μΩ	1%rdg+6dgt	0.5%rdg+4dgt	0.5%rdg +2dgt	1mA
3	1Ω	3.2000Ω	1mΩ	1%rdg+6dgt	0.5%rdg +4dgt	0.5%rdg +2dgt	100μA
4	10Ω	32.000Ω	10mΩ	1%rdg+6dgt	0.5%rdg +4dgt	0.5%rdg +2dgt	10μA
5	100Ω	320.00Ω	100mΩ	1%rdg+6dgt	0.5%rdg +4dgt	0.5%rdg +2dgt	5μA
6	1kΩ	3.2000kΩ	1Ω	1%rdg+6dgt	0.5%rdg +4dgt	0.5%rdg +2dgt	1.5μA
Open-circle voltage		24mV peak max.(when limiter is ON)					

Table 9-4 AT520SE Voltage Measurement

Range		Maximum display value	Resolution	Fast	Medium	Slow
1	6V	6.000V	1mV	0.1%rdg+6dgt	0.1%rdg+4dgt	0.1%rdg+2dgt
2	60V	60.00V	10mV	0.1%rdg+6dgt	0.1%rdg+4dgt	0.1%rdg+2dgt

9.3 AT520L Specification

Table 9-5 AT520L Resistance Measurement

Range		Maximum display value	Resolution	Fast	Medium	Slow	Meas. current
1	10mΩ	32.000mΩ	10μΩ	1%rdg+6dgt	0.5%rdg+4dgt	0.5%rdg +3dgt	9mA
2	100mΩ	320.00mΩ	100μΩ	1%rdg+6dgt	0.5%rdg+4dgt	0.5%rdg +2dgt	1mA
3	1Ω	3.2000Ω	1mΩ	1%rdg+6dgt	0.5%rdg +4dgt	0.5%rdg +2dgt	100μA
4	10Ω	32.000Ω	10mΩ	1%rdg+6dgt	0.5%rdg +4dgt	0.5%rdg +2dgt	10μA
Open-circle voltage		24mV peak max.(when limiter is ON)					

Table 9-6 AT520L Voltage Measurement

Range		Maximum display value	Resolution	Fast	Medium	Slow
1	6V	6.000V	1mV	0.1%rdg+6dgt	0.1%rdg+4dgt	0.1%rdg+2dgt
2	60V	60.00V	10mV	0.1%rdg+6dgt	0.1%rdg+4dgt	0.1%rdg+2dgt

9.4 AT520M Specification

Table 9-7 AT520M Resistance Measurement

Range		Maximum display value	Resolution	Fast	Medium	Slow	Meas. current
1	10mΩ	32.000mΩ	10μΩ	1%rdg+6dgt	0.5%rdg+4dgt	0.5%rdg +3dgt	9mA
2	100mΩ	320.00mΩ	100μΩ	1%rdg+6dgt	0.5%rdg+4dgt	0.5%rdg +2dgt	1mA
3	1Ω	3.2000Ω	1mΩ	1%rdg+6dgt	0.5%rdg +4dgt	0.5%rdg +2dgt	100μA
4	10Ω	32.000Ω	10mΩ	1%rdg+6dgt	0.5%rdg +4dgt	0.5%rdg +2dgt	10μA
Open-circle voltage		24mV peak max.(when limiter is ON)					

Table 9-8 AT520M Voltage Measurement

Range		Maximum display value	Resolution	Fast	Medium	Slow
1	10V	10.000V	1mV	0.1%rdg+6dgt	0.1%rdg+4dgt	0.1%rdg+2dgt
2	100V	100.00V	10mV	0.1%rdg+6dgt	0.1%rdg+4dgt	0.1%rdg+2dgt

9.5 General Specification

Display: Vacuum-Fluorescent-Display (4-Colors VFD) Size: 98x55mm

Display Mode: Direct reading , (Δ ABS) , (Δ %) ,(GD/NG) .

Maximum reader : AT520 Resistance 32000, voltage 50000.

AT520SE/AT520L Resistance 3200, voltage 5000.

Trigger: Internal, External and Remote (Manual).

Range Mode: Auto and Manual

Correcting: Short Clear Zero

Comparator function: Output: NG-LO, GD-IN, NG-HI , up to 30 tables.

Buzzer : GD (PASS) and NG (FAIL).

Measurement terminals : 4 terminals

Interfaces : RS232.

Handler interface (AT520SE/AT520L option)

Programming language : SCPI

Environment :

Temperature and humidity range : 15°C~35°C,80% RH or less

Operating temperature and humidity range : 10°C~40°C,10~90% RH

Storage temperature and humidity range: 0°C~50°C,10~90% RH

Power Supply : AC 95V ~ 115V, 48.5Hz ~ 62.5Hz

Fuse: 1A Slow-Blow

Maximum rated power : 15VA

Weight : 3.5kg, net

9.6 Dimensions

